

EOLO GTE10A

HIGHLY SUITABLE FOR TALL TREES

MISTBLOWERS



TOP QUALITY

Teyme equipment offers the highest level of satisfaction thanks to our great level of self-demand.



R&D

Investing on research and development is the basis of our equipment's success.



RESPECTFUL

We care for the Earth, we care for the people.

FOR THE MOST DEMANDING VEGETATION FRAMES

HUGE AIR PRESSURE

Ø1015MM WITH 3 CHANNELS

HIGHEST EFFICIENCY OF APPLICATION

 **TEYME**

FEATURES OF AIR UNIT



PROPELLER

Low consumption propeller. 10 SICKLE-profile blades with variable and progressive pitch with 8 adjustment points. TEYME's patented special design.

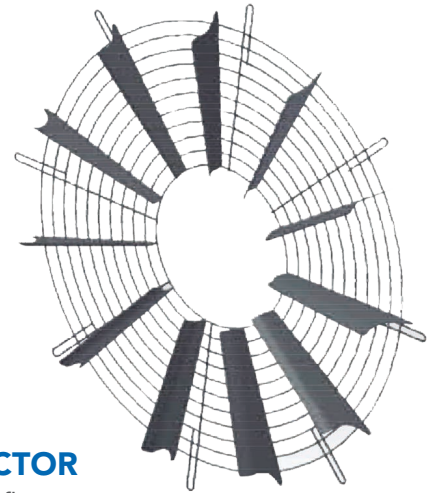

DEFLECTOR

11 blades steel rear static deflector. It provides radial air with turbulences. Distribution 50% and 50%.

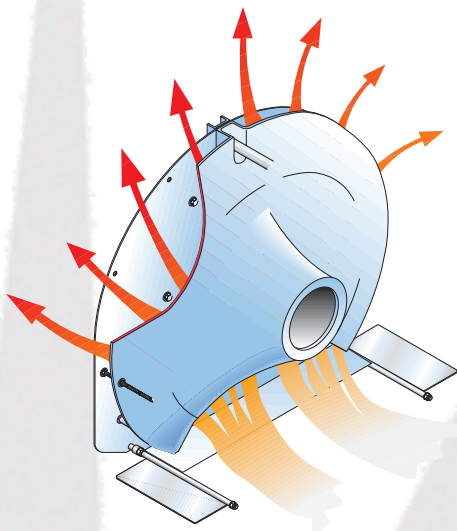

TURBO AUXILIARY CHANNEL N°4

TURBO lower channel retrieves without extra consumption a 16,50% out of the air which in other sprayers is wasted, increasing its flow rate and improving the drift effect caused by the speed of the march.

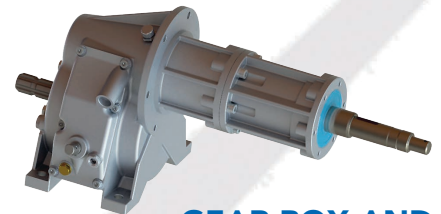

GEAR BOX AND CLUTCH

Gear box 2 speeds + neutral point. TEYME's special ratio. Capable of transferring big power. Centrifugal 3-shoes ZAMAK clutch with smooth and progressive starting.

BLOWER HOUSING WITH 3 CHANNELS

Ø1015mm X 500mm aerodynamic stainless-steel blower housing, 3 Channels A, B and C. The channels' system increases a 17% the air production. It prevents the faster upper air from bumping into the slower one of the central areas. Air exit adjustable from 22m/s to 44 m/s.

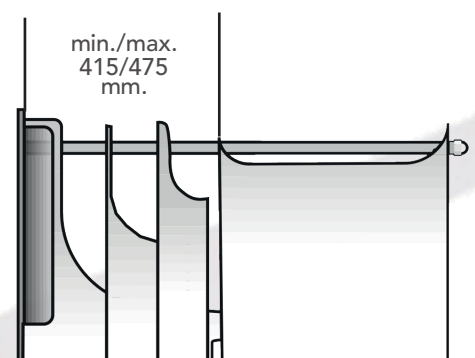

REGULATION BY SLIDING DEVICE

A, B, C channels width adjustable by means of sliding device: min. 415mm. max. 475mm. and air speeds, from 22m/sec. to 44m/sec. To adjust the treatments depending on the needs of application. TEYME's exclusive advantage Thanks to the width of the channels, it allows 50 % faster marching speeds with regards to the standard sprayers.



TANKS (EC Rules)

- Top quality and uniform thickness polyethylene tanks.
- Provided with: Main tank with two lids, rinsing auxiliary tank (10%) and sanitary water tank 18l.
- Capacities: 1.500, 2.000, 3.000 and 4.000l.
- TEYME's exclusive design complying with 9367 and 13440 ISO rules.
- Against whirlpool. Full emptying even in 10% slopes.
- Absence of dead areas. Easy rinsing.
- 2 transparent level gauges. 1 on front + 1 on side.



FILTERING

3 Levels of filtering

- 1 BASKET Filter in the filling mouth of the tank.
- 1 pump suction Filter
- 1 pressure Filtering Central



FRAME

Reinforced frame, designed in steel plate and laser-manufactured, which allow us its chain production and a perfect result, providing the machine with utmost stiffness.

AXLES

Fixed axles provided with hydraulic brake:
Center-wheel to center wheel 1.350mm in 2.000l,
1.400mm in 3.000l and 1.650mm in 4.000l.

JETS

30 jets ADOGC anti-dripping double steerable turning with stopcock closing device: with 2 ceramic nozzles per jet distributed in A and B channels.



STIRRING

33 Levels* which achieve a constant and homogeneous mixing in high, medium and low pressure.
Full sweeping of the bottom.

* Depending on the capacity of the tank.



PERFORMANCES BOARD

FAN POSITION		A 30°		B 35°		C 40°		D 45°	
GEAR BOX SPEED		I	II	I	II	I	II	I	II
RPM	PTO								
400	M3/H	48.000	57.500	56.500	68.250	65.750	79.000	75.000	90.000
	M/S	18	22	21	26	25	30	28	34
480	M3/H	55.000	66.500	65.500	79.000	76.000	91.500	86.500	103.500
	M/S	21	25	24	29	28	34	32	29
540	M3/H	61.000	73.000	72.000	87.000	93.250	100.000	95.000	112.500
	M/S	23	27	27	32	31	37	35	42



TEYME'S RANGE OF PRODUCTS

Mistblowers

Pneumatic
sprayers

Dusters

Boom sprayers

Sprayers

Humidification
and ventilation



Pol. Ind. SAU III · C/ Girona, 2
25131 TORRE-SERONA (Lleida) · SPAIN
T: (+34) 973 75 00 33 · F: (+34) 973 75 15 81
comercial@teyme.es
www.teyme.es



DEALER:

T.GTE/0A.E / 1021